

Q. 1 – Q. 20 carry one mark each

- The following is true
 - A finite signal is always bounded
 - A bounded signal always possesses finite energy
 - A bounded signal is always zero outside the interval $[-t_0, t_0]$ for some t_0
 - A bounded signal is always finite
- $x(t)$ is a real valued function of a real variable with period T . Its trigonometric Fourier Series expansion contains no terms of frequency $\omega = 2\pi(2k)/T$; $k = 1, 2, \dots$. Also, no sine terms are present. Then $x(t)$ satisfies the equation
 - $x(t) = -x(t - T)$
 - $x(t) = x(T - t) = -x(-t)$
 - $x(t) = x(T - t) = -x(t - T/2)$
 - $x(t) = x(t - T) = x(t - T/2)$
- In the figure the current source is $1 \angle 0$ A, $R = 1\Omega$, the impedances are $Z_C = -j\Omega$, and $Z_L = 2j\Omega$. The Thevenin equivalent looking into the circuit across X-Y is

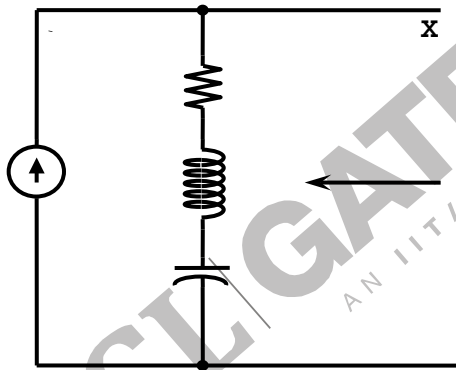

- $\sqrt{2} \angle 0$ V, $(1 + 2j) \Omega$
 - $2 \angle 45^\circ$ V, $(1 - 2j) \Omega$
 - $2 \angle 45^\circ$ V, $(1 + j) \Omega$
 - $\sqrt{2} \angle 45^\circ$ V, $(1 + j) \Omega$
- The three limbed non ideal core shown in the figure has three windings with nominal inductances L each when measured individually with a single phase AC source. The inductance of the windings as connected will be

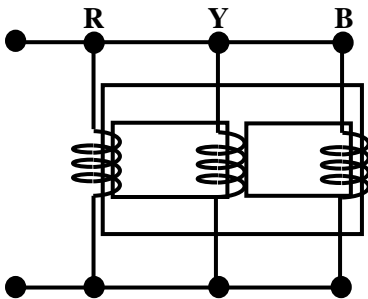

-
- (A) very low (C) 3L
(B) $L/3$ (D) very high
5. Which of the following statements holds for the divergence of electric and magnetic flux densities?
(A) Both are zero
(B) These are zero for static densities but non zero for time varying densities
(C) It is zero for the electric flux density
(D) It is zero for the magnetic flux density
6. In transformers, which of the following statements is valid?
(A) In an open circuit test, copper losses are obtained while in short circuit test, core losses are obtained
(B) In an open circuit test, current is drawn at high power factor
(C) In a short circuit test, current is drawn at zero power factor
(D) In an open circuit test, current is drawn at low power factor
7. For a single phase capacitor start induction motor which of the following statements is valid?
(A) The capacitor is used for power factor improvement
(B) The direction of rotation can be changed by reversing the main winding terminals
(C) The direction of rotation cannot be changed
(D) The direction of rotation can be changed by interchanging the supply terminals
8. In a DC machine, which of the following statements is true?
(A) Compensating winding is used for neutralizing armature reaction while interpole winding is used for producing residual flux
(B) Compensating winding is used for neutralizing armature reaction while interpole winding is used for improving commutation
(C) Compensating winding is used for improving commutation while interpole winding is used for neutralizing armature reaction
(D) Compensating winding is used for improving commutation while interpole winding is used for producing residual flux
9. The concept of an electrically short, medium, and long line is primarily based on the
(A) nominal voltage of the line (C) wavelength of the line
(B) physical length of the line (D) power transmitted over the line
10. Keeping in view the cost and overall effectiveness, the following circuit breaker is best suited for capacitor bank switching
(A) vacuum (C) SF_6
(B) air blast (D) Oil

11. In a biased differential relay, the bias is defined as a ratio of
- number of turns of restraining and operating coil
 - operating coil current and restraining coil current
 - fault current and operating coil current
 - fault current and restraining coil current
12. An HVDC link consists of rectifier, inverter transmission line and other equipments. Which one of the following is true for this link?
- The transmission line produces/supplies reactive power
 - The rectifier consumes reactive power and the inverter supplies reactive power from / to the respective connected AC systems
 - Rectifier supplies reactive power and the inverter consumes reactive power to / from the respective connected AC systems
 - Both the converters (rectifier and inverter) consume reactive power from the respective connected AC systems

13. For a system with the transfer function

$$H(s) = \frac{3(s-2)}{4s^2 - 2s + 1}, \text{ the matrix } A \text{ in the state space form } \dot{x} = Ax + Bu \text{ is equal to}$$

(A) $\begin{bmatrix} 1 & 0 & 0 \\ 0 & 1 & 0 \\ -1 & 2 & -4 \end{bmatrix}$

(B) $\begin{bmatrix} 0 & 1 & 0 \\ 0 & 0 & 1 \\ -1 & 2 & -4 \end{bmatrix}$

(C) $\begin{bmatrix} 0 & 1 & 0 \\ 3 & -2 & 1 \\ 1 & -2 & 4 \end{bmatrix}$

(D) $\begin{bmatrix} 0 & 1 & 0 \\ 0 & 0 & 1 \\ -1 & 2 & -4 \end{bmatrix}$

14. A discrete real all pass system has a pole at $z = 2 \angle 30^\circ$: it, therefore
- also has a pole at $\frac{1}{2} \angle 30^\circ$
 - has a constant phase response over the z-plane: $\arg |H(z)| = \text{constant}$
 - is stable only, if it is anti causal
 - has a constant phase response over the unit circle: $\arg |H(e^{j\Omega})| = \text{constant}$
15. The time / div and voltage / div axes of an oscilloscope have been erased. A student connects a 1 kHz, 5V p-p square wave calibration pulse to channel 1 of the scope and observes the screen to be as shown in the upper trace of the figure. An unknown signal is connected to channel 2 (lower trace) of the scope. If the time/div and V/div on both channels are the same, the amplitude (p-p) and period of the unknown signal are respectively

- (A) 5 V, 1 ms
- (B) 5 V, 2 ms
- (C) 7.5 V, 2 ms
- (D) 10 V, 1 ms

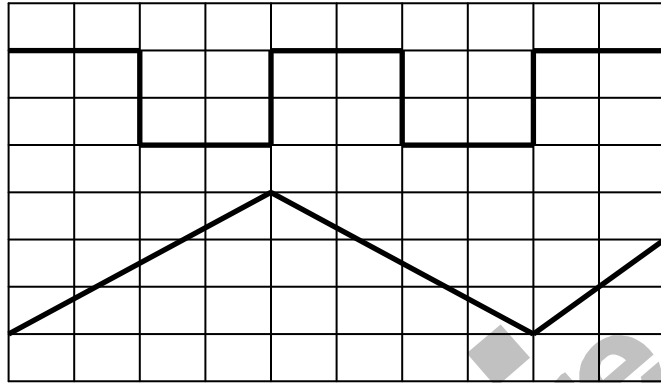

16. A sampling wattmeter (that computes power from simultaneously sampled values of voltage and current) is used to measure the average power of a load. The peak to peak voltage of the square wave is 10 V and the current is a triangular wave of 5 A p-p as shown in the figure. The period is 20 ms. The reading in W will be

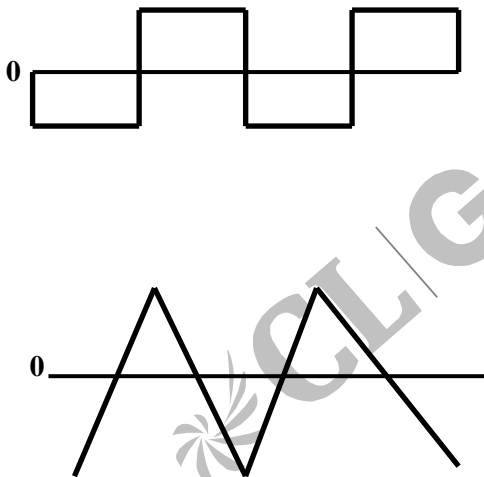

- (A) 0 W
- (B) 25 W
- (C) 50 W
- (D) 100 W

17. What are the states of the three ideal diodes of the circuit shown in figure?

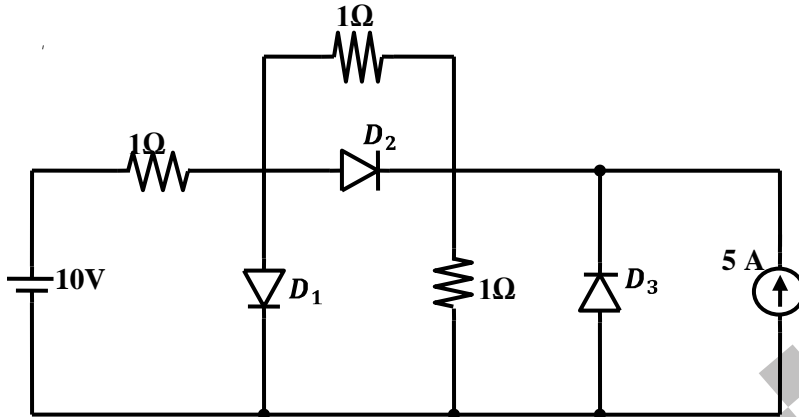

- (A) D_1 ON, D_2 OFF, D_3 OFF
 (B) D_1 OFF, D_2 ON, D_3 OFF
 (C) D_1 ON, D_2 OFF, D_3 ON
 (D) D_1 OFF, D_2 ON, D_3 ON

18. The speed of a 3 – phase, 440 V, 50 Hz induction motor is to be controlled over a wide range from zero speed to 1.5 time the rated speed using a 3-phase voltage source inverter. It is desired to keep the flux in the machine constant in the constant torque region by controlling the terminal voltage as the frequency changes. The inverter output voltage vs frequency characteristic should be

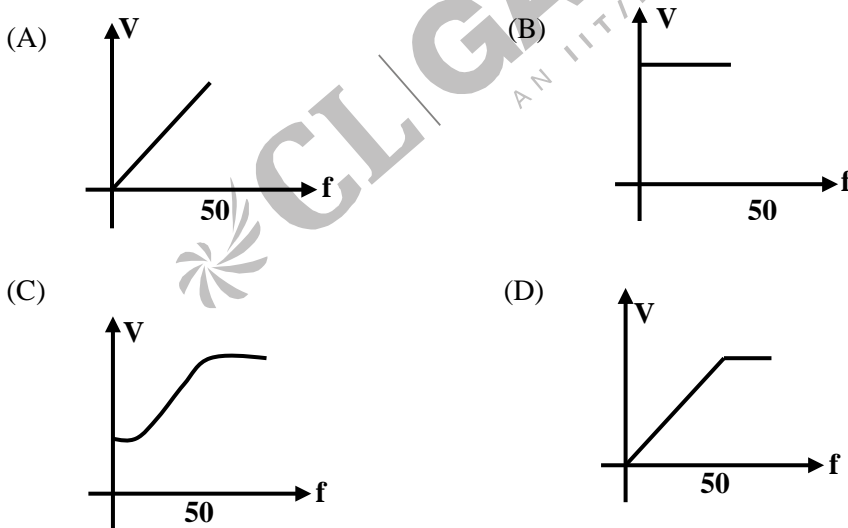

19. For a given sinusoidal input voltage, the voltage waveform at point P of the clamper circuit shown in figure will be

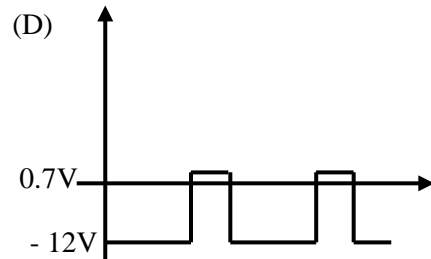
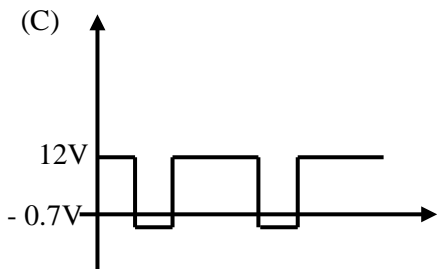
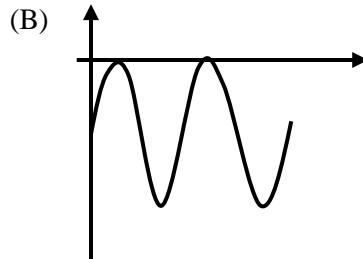
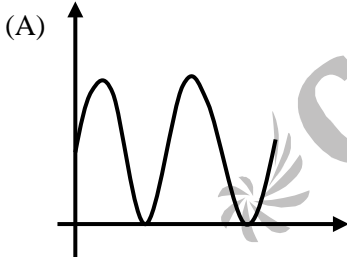
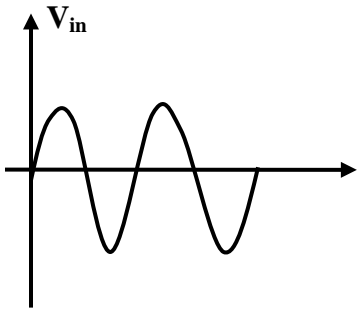
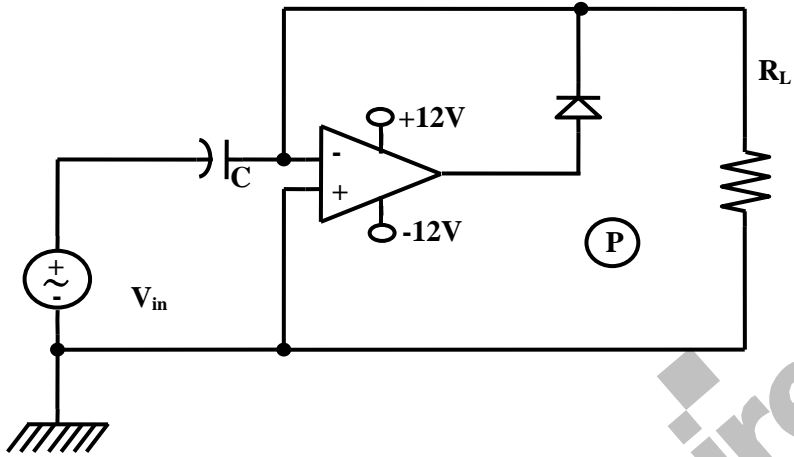

20. A single – phase half wave uncontrolled converter circuit is shown in figure. A 2 – winding transformer is used at the input for isolation. Assuming the load current to be constant and $v = V_m \sin \omega t$, the current waveform through diode D_2 will be

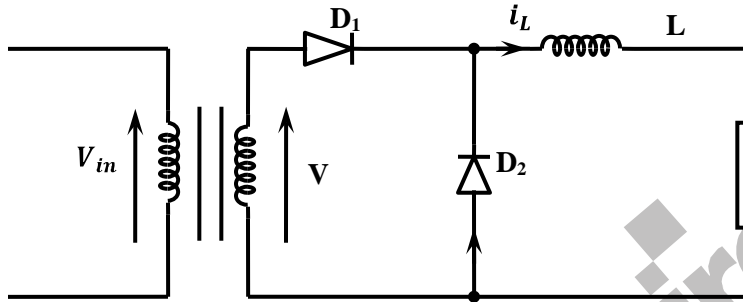

(A)

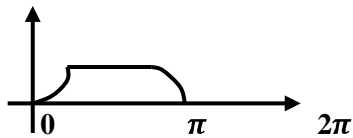

(B)

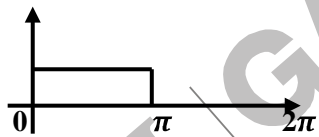

(C)

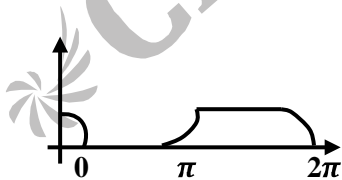

(D)

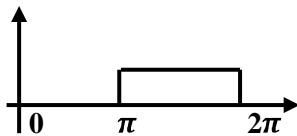

Q. 21 to Q. 75 carry two marks each.

21. $x[n] = 0; n < -1, n > 0, x[-1] = -1, x[0] = 2$ is the input and $y[n] = 0; n < -1, n > 2, y[-1] = -1 = y[1], y[0] = 3, y[2] = -2$ is the output of a discrete – time LTI system. The system impulse response $h[n]$ will be
- (A) $h[n] = 0; n < 0, n > 2, h[0] = 1, h[1] = h[2] = -1$
 (B) $h[n] = 0; n < -1, n > 1, h[-1] = 1, h[0] = h[1] = 2$
 (C) $h[n] = 0; n < 0, n > 3, h[0] = -1, h[1] = 2, h[2] = 1$
 (D) $h[n] = 0; n < -2, n > 1, h[-2] = h[1] = h[-1] = -h[0] = 3$
22. The expression $V = \int_0^H \pi R^2 (1 - h/H)^2 dh$ for the volume of a cone is equal to
- (A) $\int_0^R \pi R^2 (1 - h/H)^2 dr$
 (B) $\int_0^R \pi R^2 (1 - h/H)^2 dh$
 (C) $\int_0^H 2\pi r H(1 - r/R) dh$
 (D) $\int_0^R 2\pi r H(1 - \frac{r}{R})^2 dr$
23. The discrete – time signal $x[n] \leftrightarrow X(Z) = \sum_{n=0}^{\infty} \frac{3^n}{2+n} Z^{2n}$, where \leftrightarrow denotes a transform – pair relationship, is orthogonal to the signal
- (A) $y_1[n] \leftrightarrow Y_1(Z) = \sum_{n=0}^{\infty} \left(\frac{2}{3}\right)^n Z^{-n}$
 (B) $y_2[n] \leftrightarrow Y_2(Z) = \sum_{n=0}^{\infty} (5^n - n) Z^{-(2n+1)}$
 (C) $y_3[n] \leftrightarrow Y_3(Z) = \sum_{n=-\infty}^{\infty} 2^{-|n|} Z^{-n}$
 (D) $y_4[n] \leftrightarrow Y_4(Z) = 2Z^{-4} + 3Z^{-2} + 1$
24. A surface $S(x,y) = 2x + 5y - 3$ is integrated once over a path consisting of the points that satisfy $(x+1)^2 + (y-1)^2 = \sqrt{2}$. The integral evaluates to
- (A) $17\sqrt{2}$ (C) $\sqrt{2}/17$
 (B) $17/\sqrt{2}$ (D) 0
25. A continuous – time system is described by $y(t) = e^{-|x(t)|}$, where $y(t)$ is the output and $x(t)$ is the input. $y(t)$ is bounded
- (A) only when $x(t)$ is bounded
 (B) only when $x(t)$ is non – negative
 (C) only for $t \geq 0$ if $x(t)$ is bounded for $t \geq 0$
 (D) even when $x(t)$ is not bounded

26. The running integrator, given by $y(t) = \int_{-\infty}^t x(t') dt'$
- (A) has no finite singularities in its double sided Laplace Transform $Y(s)$
 - (B) produces a bounded output for every causal bounded input
 - (C) produces a bounded output for every anti causal bounded input
 - (D) has no finite zeroes in its double sided Laplace Transform $Y(s)$
27. Two fair dice are rolled and the sum r of the numbers turned up is considered
- (A) $\Pr(r > 6) = \frac{1}{6}$
 - (B) $\Pr(r/3 \text{ is an integer}) = \frac{5}{6}$
 - (C) $\Pr(r = 8 \mid r/4 \text{ is an integer}) = \frac{5}{9}$
 - (D) $\Pr(r = 6 \mid r/5 \text{ is an integer}) = \frac{1}{18}$
28. The parameters of the circuit shown in the figure are $R_i = 1 \text{ M}\Omega$, $R_o = 10 \Omega$, $A = 10^6 \text{ V/V}$. If $V_i = 1 \mu\text{V}$, then output voltage, input impedance and output impedance respectively are

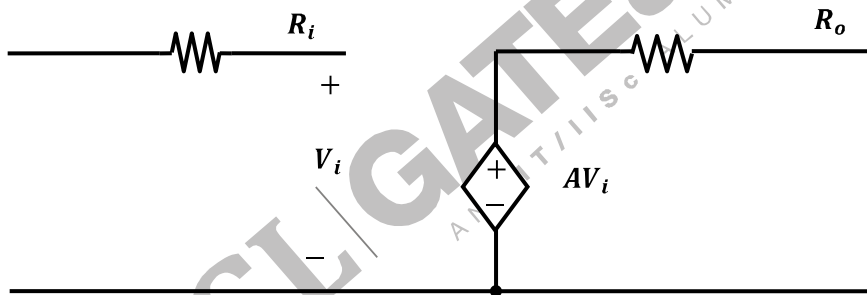

- (A) $1\text{V}, \infty, 10 \Omega$
 - (B) $1 \text{ V}, 0, 10\Omega$
 - (C) $1 \text{ V}, 0, \infty$
 - (D) $10 \text{ V}, \infty, 10\Omega$
29. In the circuit shown in the figure, the current source $I = 1\text{A}$, voltage source $V = 5\text{V}$,
 $R_1 = R_2 = R_3 = 1 \text{ W}$, $L_1 = L_2 = L_3 = 1\text{H}$,
 $C_1 = C_2 = 1\text{F}$.
 The currents (in A) through R_3 and the voltage source V respectively will be

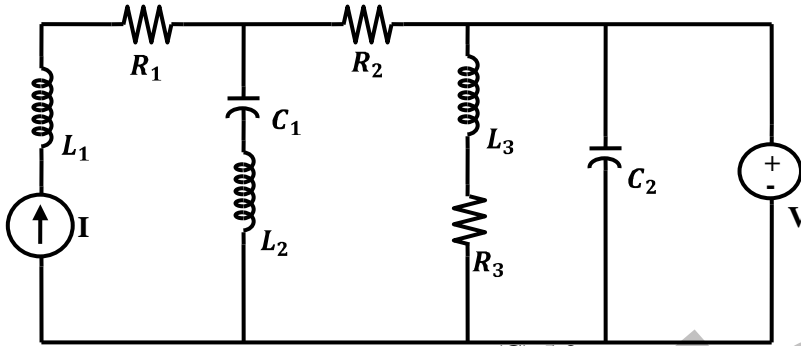

- (A) 1,4
 (B) 5,1
 (C) 5,2
 (D) 5,4

30. The parameter type and the matrix representation of the relevant two port parameters that describe the circuit shown are

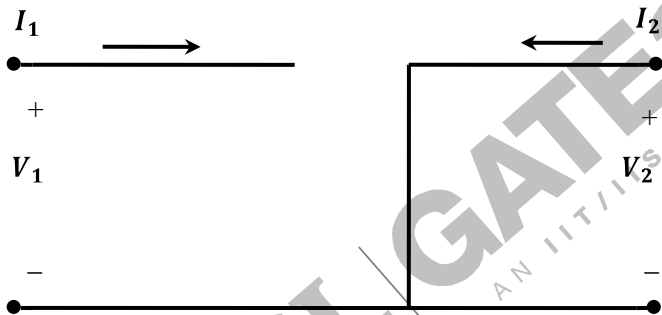

- (A) z parameters, $\begin{bmatrix} 0 & 0 \\ 0 & 0 \end{bmatrix}$
 (B) h parameters, $\begin{bmatrix} 1 & 0 \\ 0 & 1 \end{bmatrix}$
 (C) h parameters, $\begin{bmatrix} 0 & 0 \\ 0 & 0 \end{bmatrix}$
 (D) z parameters, $\begin{bmatrix} 1 & 0 \\ 0 & 1 \end{bmatrix}$

31. Consider the following statements with reference to the equation $\frac{\delta p}{\delta t}$
- (1) This is a point form of the continuity equation
 - (2) Divergence of current density is equal to the decrease of charge per unit volume per unit at every point
 - (3) This is Maxwell's divergence equation
 - (4) This represents the conservation of charge
- Select the correct answer.
- (A) Only 2 and 4 are true
 (B) 1,2 and 3 are true
 (C) 2,3 and 4 are true
 (D) 1,2 and 4 are true

32. The circuit shown in the figure is energized by a sinusoidal voltage source V_1 at a frequency which causes resonance with a current of I .

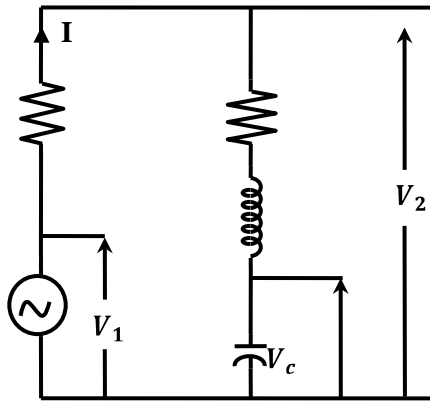

The phasor diagram which is applicable to this circuit is

(A)

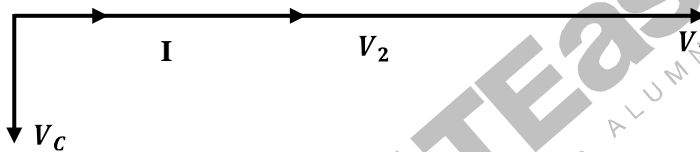

(B)

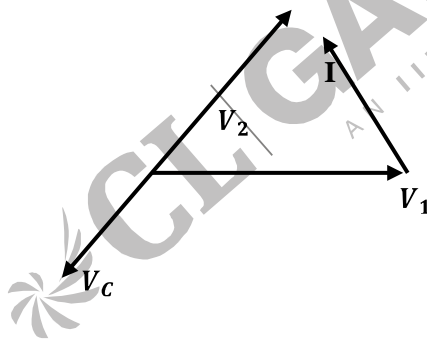

(C)

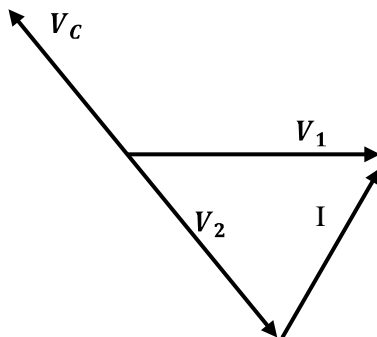

(D)

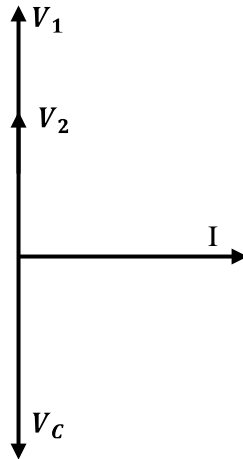

33. An ideal capacitor is charged to a voltage V_0 and connected at $t = 0$ across an ideal inductor L . (The circuit now consists of a capacitor and inductor alone). If we let $\omega_0 = \frac{1}{\sqrt{LC}}$, the voltage across the capacitor at time $t > 0$ is given by
- (A) V_0 (C) $V_0 \sin(\omega_0 t)$
 (B) $V_0 \cos(\omega_0 t)$ (D) $V_0 e^{-\omega_0 t} \cos(\omega_0 t)$
34. A 400 V, 50 Hz, three phase balanced source supplies power to a star connected load whose rating is $12\sqrt{3}$ k VA, 0.8 pf (lag). The rating (in kVAR) of the delta connected (capacitive) reactive power bank necessary to bring the pf to unity is
- (A) 28.78 (C) 16.60
 (B) 21.60 (D) 12.47
35. An energy meter connected to an immersion heater (resistive) operating on an AC 230 V, 50 Hz, AC single phase source reads 2.3 units (kWh) in 1 hour. The heater is removed from the supply and now connected to a 400 V peak to peak square wave source of 150 Hz. The power in kW dissipated by the heater will be
- (A) 3.478 (C) 1.540
 (B) 1.739 (D) 0.870
36. A 220 V DC machine supplies 20 A at 200 V as a generator. The armature resistance is 0.2 ohm. If the machine is now operated as a motor at same terminal voltage and current but with the flux increased by 10%, then ratio of motor speed to generator speed is
- (A) 0.87 (C) 0.96
 (B) 0.95 (D) 1.06

37. A synchronous generator is feeding a zero power factor (lagging) load at rated current. The armature reaction is
- (A) magnetizing (C) cross – magnetizing
(B) demagnetizing (D) ineffective
38. Two transformers are to be operated in parallel such that they share load in proportion to their kVA ratings. The rating of the first transformer is 500 kVA and its pu leakage impedance is 0.05 pu. If the rating of second transformer is 250 kVA, then its pu leakage impedance is
- (A) 0.20 (C) 0.05
(B) 0.10 (D) 0.025
39. The speed of a 4-pole induction motor is controlled by varying the supply frequency while maintaining the ratio of supply voltage to supply frequency (V/f) constant. At rated frequency of 50 Hz and rated voltage of 400 V its speed is 1440 rpm. Find the speed at 30 Hz, if the load torque is constant.
- (A) 882rpm (C) 840 rpm
(B) 864 rpm (D) 828 rpm
40. A 3 phase, 4 pole, 400 V, 50 Hz star connected induction motor has following circuit parameters $r_1 = 1.0\Omega$, $r_2' = 0.5\Omega$, $x_1 = x_2' = 1.2\Omega$, $x_m = 35\Omega$. The starting torque when the motor is started direct – on – line is (use approximate equivalent circuit model)
- (A) 63.6 Nm (C) 190.8 Nm
(B) 74.3 Nm (D) 222.9 Nm
41. A 3 phase, 10 kW, 400 V, 4 pole, 50 Hz, star connected induction motor draws 20 A on full load. Its no load and blocked rotor test data are given below :
- | | | | |
|----------------------|------|------|--------|
| No Load test : | 400V | 6A | 1002 W |
| Blocked Rotor test : | 90 V | 15 A | 762 W |
- Neglecting copper loss in no Load test and core loss in Blocked Rotor test, estimate motor's full load efficiency.
- (A) 76 % (C) 82.4 %
(B) 81 % (D) 85 %
42. A 3 phase, 400 V, 5 kW, star connected synchronous motor having an internal reactance of 10Ω is operating at 50% load, unity pf. Now, the excitation is increased by 1%. What will be the new load in percent, if the power factor is to be kept same? Neglect all losses and consider linear magnetic circuit.

- (A) 67.9% (C) 51%
(B) 56.9% (D) 50%
43. The A, B, C, D constants of a 220 kV line are: $A = D = 0.94 \angle 1^\circ$, $B = 130 \angle 73^\circ$, $C = 0.001 \angle 90^\circ$. If the sending end voltage of the line for a given load delivered at nominal voltage is 240 kV, then % voltage regulation of the line is
(A) 5 (C) 16
(B) 9 (D) 21
44. A single phase transmission line and a telephone line are both symmetrically strung one below the other, in horizontal configurations, on a common tower. The shortest and longest distances between the phase and telephone conductors are 2.5m and 3m respectively. The voltage (volt/km) induced in the telephone circuit, due to 50 Hz current of 100 amps in the power circuit is
(A) 4.81 (C) 2.29
(B) 3.56 (D) 1.27
45. Three identical star connected resistors of 1.0 pu are connected to an unbalanced 3 phase supply. The load neutral is isolated. The symmetrical components of the line voltages in pu are: $V_{ab1} = X \angle \theta_1$, $V_{ab2} = Y \angle \theta_2$. If all the pu calculations are with the respective base values, the phase to neutral sequence voltages are
(A) $V_{an1} = X \angle (\theta_1 + 30^\circ)$, $V_{an2} = Y \angle (\theta_2 - 30^\circ)$,
(B) $V_{an1} = X \angle (\theta_1 - 30^\circ)$, $V_{an2} = Y \angle (\theta_2 + 30^\circ)$,
(C) $V_{an1} = \frac{1}{\sqrt{3}} X \angle (\theta_1 - 30^\circ)$
 $V_{an2} = \frac{1}{\sqrt{3}} Y \angle (\theta_2 - 30^\circ)$,
(D) $V_{an1} = \frac{1}{\sqrt{3}} X \angle (\theta_1 - 60^\circ)$,
 $V_{an2} = \frac{1}{\sqrt{3}} Y \angle (\theta_2 - 60^\circ)$
46. A generator is connected through a 20 MVA, 13.8/138 kV step down transformer, to a transmission line. At the receiving end of the line a load is supplied through a step down transformer of 10 MVA, 138/69 kV rating. A 0.72 pu load, evaluated on load side transformer ratings as base values, is supplied from the above system. For system base values of 10 MVA and 69 kV in load circuit, the value of the load (in per unit) in generator circuit will be
(A) 36 (C) 0.72
(B) 1.44 (D) 0.18

47. The Gauss Seidel load flow method has following disadvantages. Tick the incorrect statement.

- (A) Unreliable convergence
- (B) Slow convergence
- (C) Choice of slack bus affects convergence
- (D) A good initial guess for voltages is essential for convergence

48. The Bode magnitude plot of

$$H(j\omega) = \frac{10^4(1+j\omega)}{(10+j\omega)(100+j\omega)^2}$$
 is

(A)

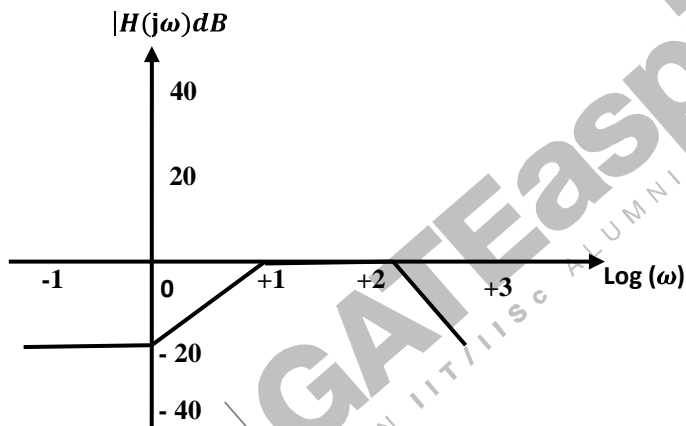

(B)

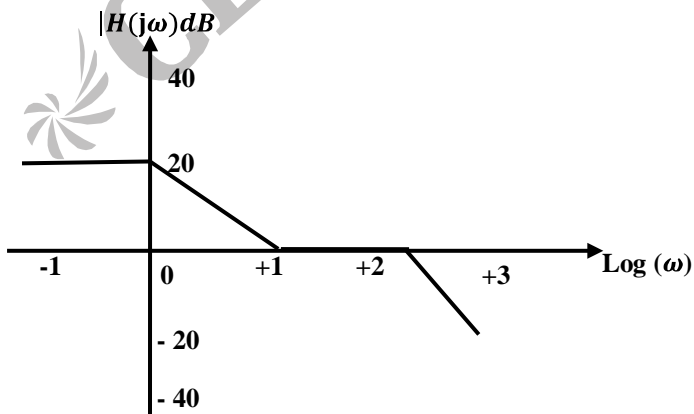

(C)

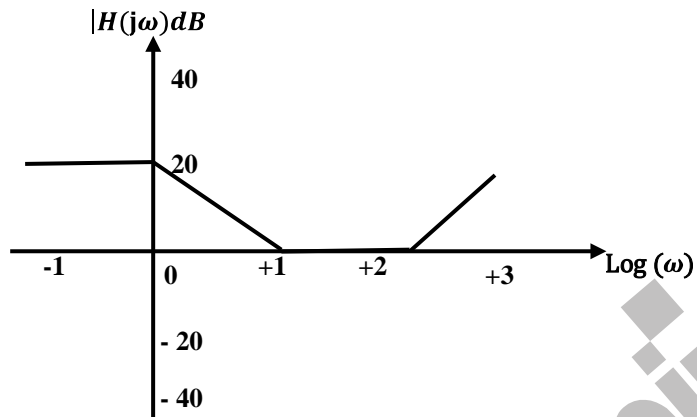

(D)

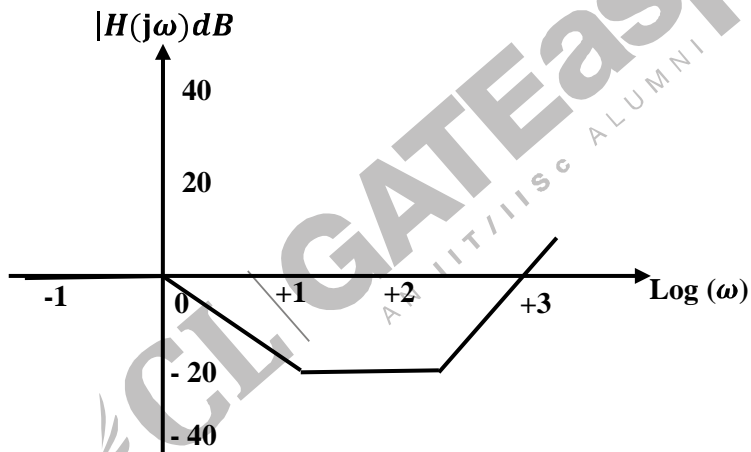

49. A Closed – loop system has the characteristic function $(s^2 - 4)(s + 1) + K(s - 1) = 0$. Its root locus plot against K is

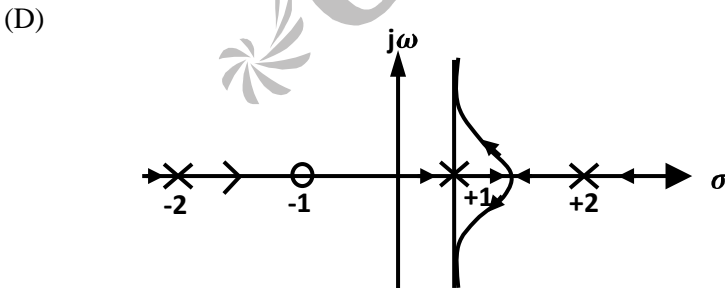
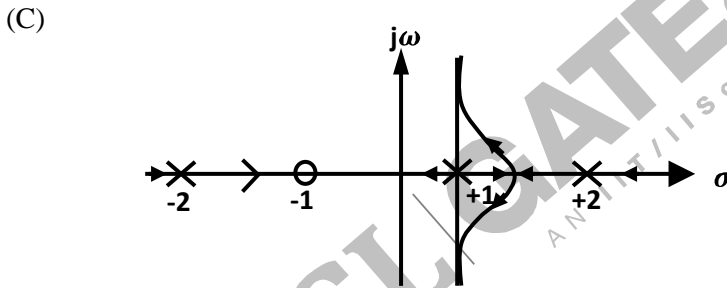
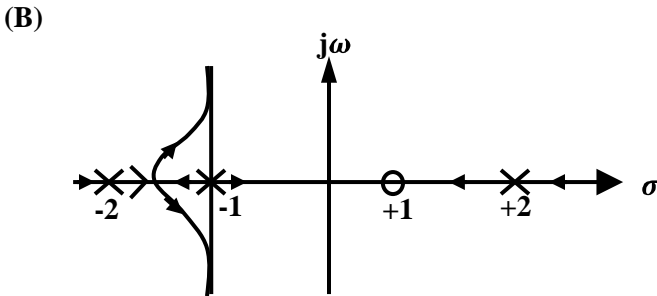
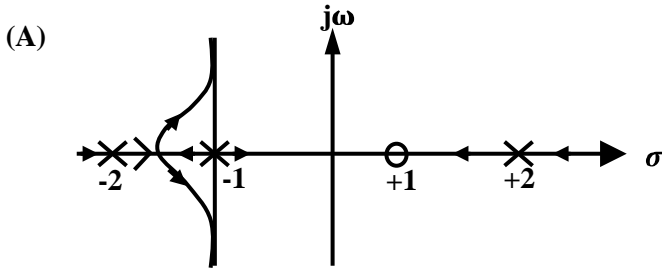

50. $y[n]$ denotes the output and $x[n]$ denotes the input of a discrete – time system given by the difference equation $y[n] - 0.8 y[n - 1] = x[n] + 1.25 x[n + 1]$.

Its right – sided impulse response is

- (A) causal
- (B) unbounded
- (C) periodic
- (D) non – negative

51. The algebraic equation

$F(s) = s^5 - 3s^4 + 5s^3 - 7s^2 + 4s + 20$ is given. $F(s) = 0$ has

- (A) a single complex root with the remaining roots being real
 (B) one positive real root and four complex roots, all with positive real parts
 (C) one negative real root, two imaginary roots, and two roots with positive real parts
 (D) one positive real root, two imaginary roots, and two roots with negative real parts
52. Consider the following Nyquist plots of loop transfer functions over $\omega = 0$ to $\omega = \infty$. Which of these plots represents a stable closed loop system?

(1)

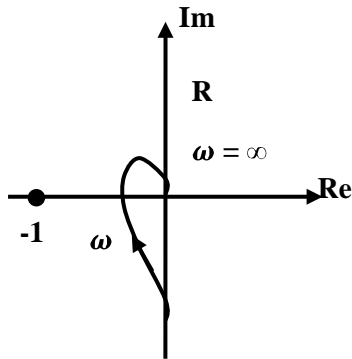

(2)

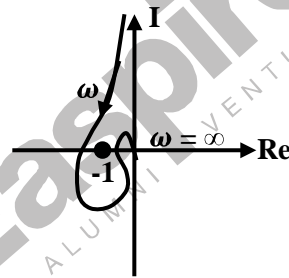

(3)

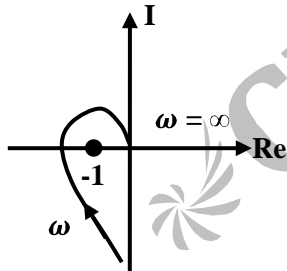

(4)

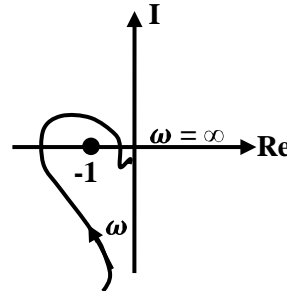

- (A) (1) only
 (B) all, except (1)

- (C) all, except (3)
 (D) (1) and (2) only

53. A current of $-8 + 6\sqrt{2}(\sin \omega t + 30^\circ)$ A is passed through three meters. They are a centre zero PMMC meter, a true rms meter and a moving iron instrument. The respective readings (in A) will be

- (A) 8, 6, 10
 (B) 8, 6, 8
 (C) -8, 10, 10
 (D) -8, 2, 2

54. A variable w is related to three other variables x, y, z as $w = xy/z$. The variables are measured with meters of accuracy $\pm 0.5\%$ reading, $\pm 1\%$ of full scale value and $\pm 1.5\%$ reading. The actual readings of the three meters are 80, 20 and 50 with 100 being the full scale value for all three. The maximum uncertainty in the measurement of w will be
- (A) $\pm 0.5\%$ rdg (C) $\pm 6.7\%$ rdg
 (B) $\pm 5.5\%$ rdg (D) $\pm 7.0\%$ rdg
55. A 200/1 Current transformer (CT) is wound with 200 turns on the secondary on a toroidal core. When it carries a current of 160 A on the primary, the ratio and phase errors of the CT are found to be -0.5% and 30 minutes respectively. If the number of secondary turns is reduced by 1 the new ratio error (%) and phase error (min) will be respectively
- (A) 0.0, 30 (C) -1.0, 30
 (B) -0.5, 35 (D) -1.0, 25
56. R_1 and R_4 are the opposite arms of a Wheatstone bridge as are R_3 and R_2 . The source voltage is applied across R_1 and R_3 . Under balanced conditions which one of the following is true?
- (A) $R_1 = R_3 R_4 / R_2$ (C) $R_1 = R_2 R_4 / R_3$
 (B) $R_1 = R_2 R_3 / R_4$ (D) $R_1 = R_2 + R_3 + R_4$
57. Assuming the diodes D_1 and D_2 of the circuit shown in figure to be ideal ones, the transfer characteristics of the circuit will be

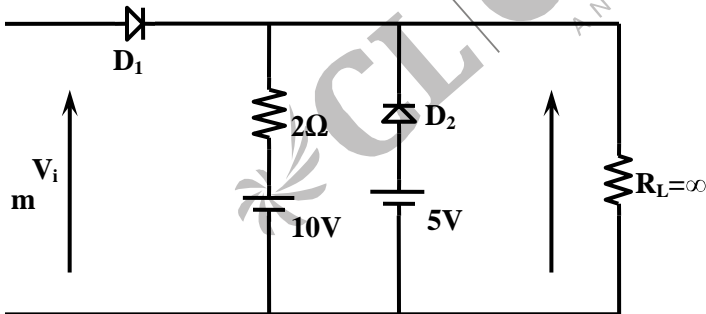

(A)

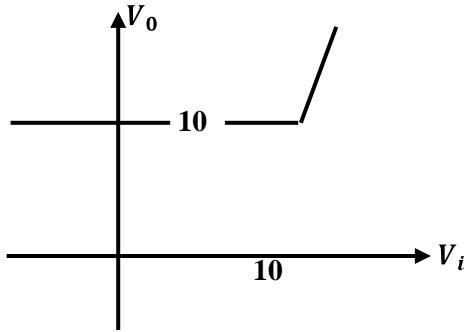

(B)

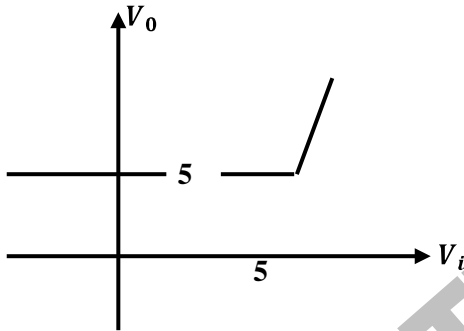

(C)

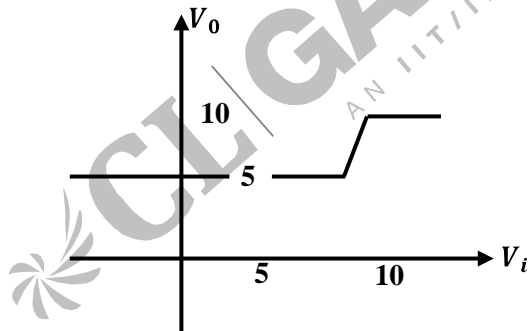

(D)

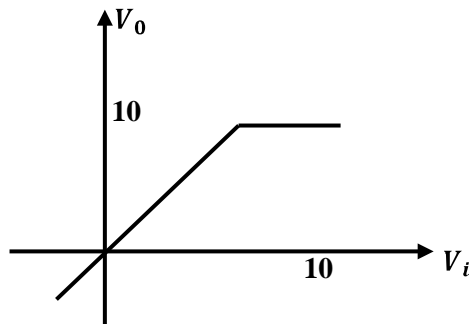

58. Consider the circuit shown in figure. If the β of the transistor is 30 and I_{CBO} is 20 n A and the input voltage is + 5 V, then transistor would be operating in

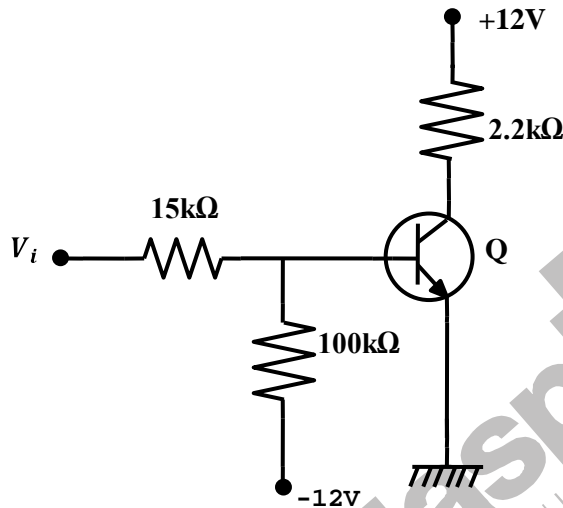

- (A) saturation region
- (B) active region
- (C) breakdown region
- (D) cut – off region

59. A relaxation oscillator is made using OPAMP as shown in figure. The supply voltages of the OPAMP are $\pm 12V$. The voltage waveform at point P will be

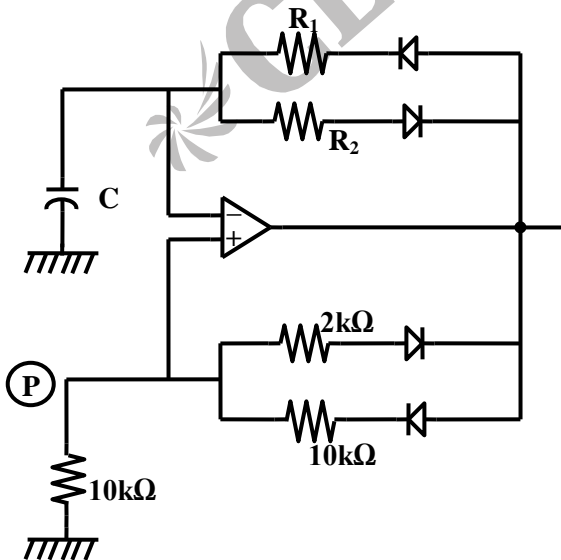

(A)

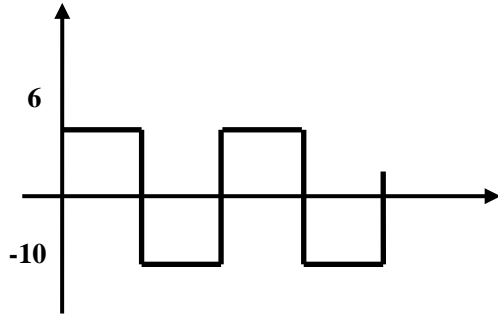

(B)

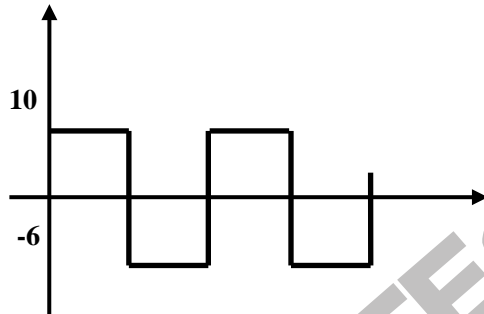

(C)



(D)

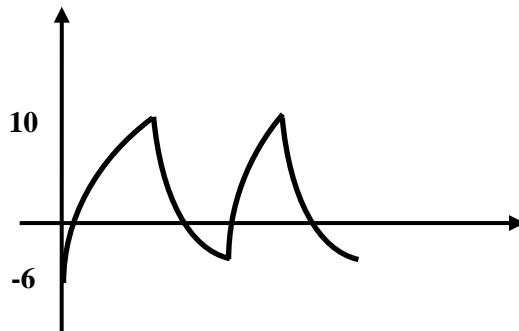

60. A TTL NOT gate circuit is shown in figure. Assuming $V_{BE} = 0.7 \text{ V}$ of both the transistors, if $V_i = 3.0 \text{ V}$, then the states of the two transistors will be

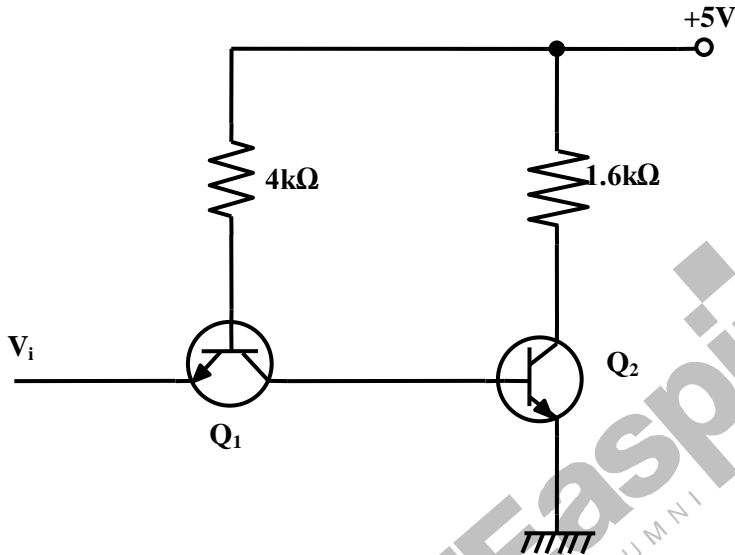

- (A) Q_1 ON and Q_2 OFF
 - (B) Q_1 reverse ON and Q_2 OFF
 - (C) Q_1 reverse ON and Q_2 ON
 - (D) Q_1 OFF and Q_2 reverse ON
61. A student has made a 3 – bit binary down counter and connected to the R – 2R ladder type DAC [Gain = $(-1 \text{ K}\Omega/2R)$] as shown in figure to generate a staircase waveform. The output achieved is different as shown in figure. What could be the possible cause of this error?

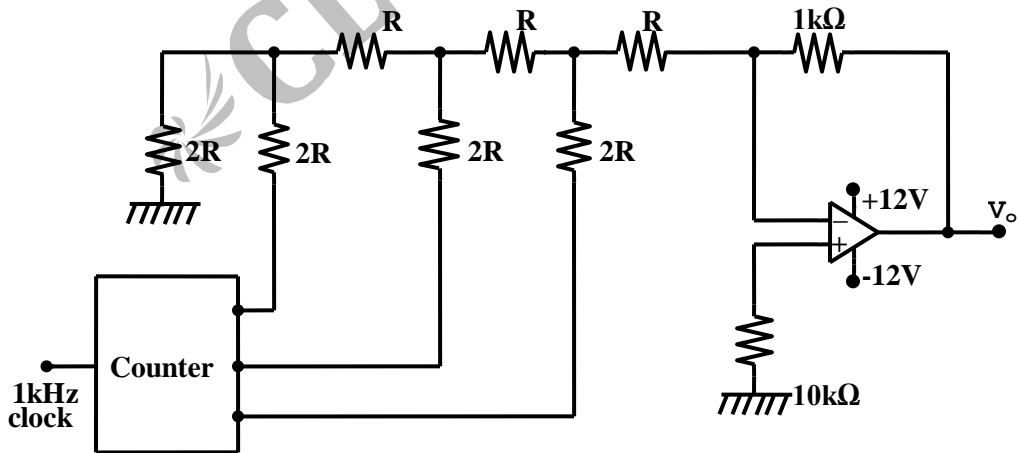

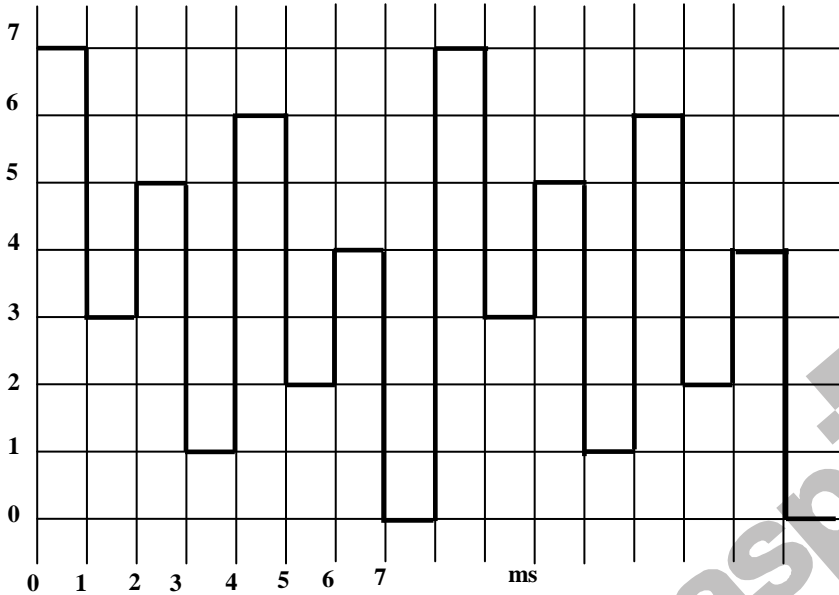

- (A) The resistance values are incorrect
- (B) The counter is not working properly
- (C) The connection from the counter to DAC is not proper
- (D) The R and 2R resistances are interchanged

62. A 4×1 MUX is used to implement a 3 – input Boolean function as shown in figure. The Boolean function $F(A,B,C)$ implemented is

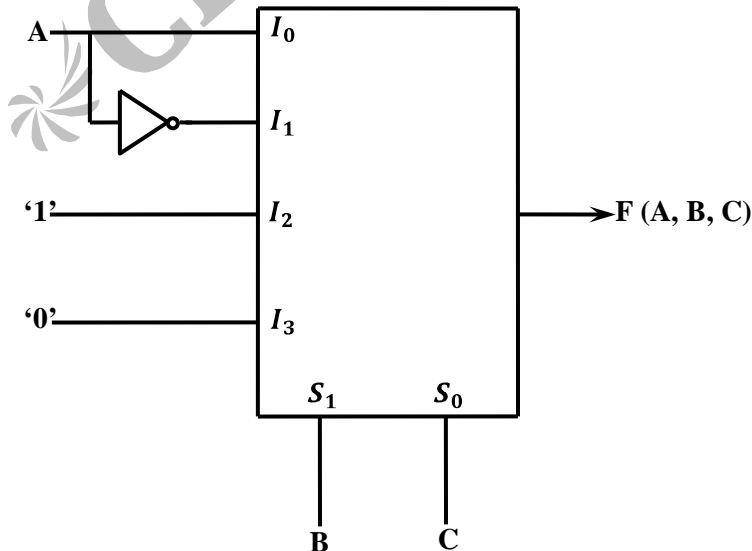

(A) $F(A, B, C) = \Sigma(1, 2, 4, 6)$

(C) $F(A, B, C) = \Sigma(2, 4, 5, 6)$

(B) $F(A, B, C) = \Sigma(1, 2, 6)$

(D) $F(A, B, C) = \Sigma(1, 5, 6)$

63. A software delay subroutine is written as given below:

```

DELAY:      MVI      H,      255 D
              MVI      L,      255 D
LOOP:      DCR      L
              JNZ      LOOP
              DCR      H
              JNZ      LOOP

```

How many times DCR L instruction will be executed?

(A) 255

(C) 65025

(B) 510

(D) 65279

64. In an 8085 A microprocessor based system, it is desired to increment the contents of memory location whose address is available in (D, E) register pair and store the result in same location.

The sequence of instructions is

- (A) XCHG
INR M
- (B) XCHG
INX H
- (C) INX D
XCHG
- (D) INR M
XCHG

65. A single- phase inverter is operated in PWM mode generating a single-pulse of width $2d$ in the centre of each half cycle as shown in figure. It is found that the output voltage is free from 5th harmonic for pulse width 144° . What will be percentage of 3rd harmonic present in the output voltage (V_{o3}/V_{o1max})?

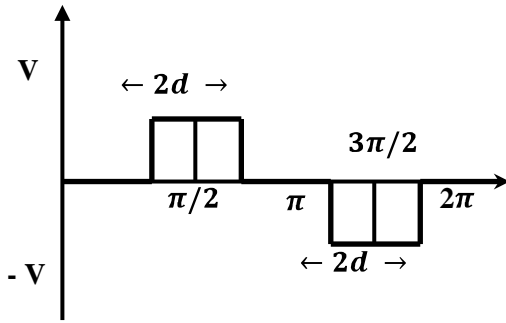

- (A) 0.0%
- (B) 19.6%
- (C) 31.7%
- (D) 53.9%

66. A 3- phase fully controlled bridge converter with free wheeling diode is fed from 400 V, 50 Hz AC source and is operating at a firing angle of 60° . The load current is assumed constant at 10 A due to high load inductance. The input displacement factor (IDF) and the input power factor (IPF) of the converter will be

- (A) IDF = 0.867 IPF = 0.828
- (B) IDF = 0.867 IPF = 0.552
- (C) IDF = 0.5 IPF = 0.478
- (D) IDF = 0.5 IPF = 0.318

67. A voltage commutation circuit is shown in figure. If the turn off time of the SCRs is $50 \mu\text{sec}$ and a safety margin of 2 is considered, then what will be the approximate minimum value of capacitor required for proper commutation?

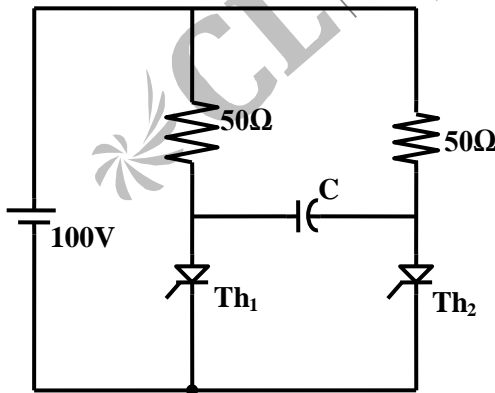

- (A) $2.88 \mu\text{F}$
- (B) $1.44 \mu\text{F}$
- (C) $0.91 \mu\text{F}$
- (D) $0.72 \mu\text{F}$

68. A solar cell of 350 V is feeding power to an ac supply of 440 V, 50 Hz through a 3 – phase fully controlled bridge converter. A large inductance is connected in the dc circuit to maintain the dc current at 20 A. If the solar cell resistance is 0.5Ω , then each thyristor will be reverse biased for a period of

- (A) 125° (C) 60°
 (B) 120° (D) 55°

69. A single – phase bridge converter is used to charge a battery of 200 V having an internal resistance of 0.2Ω as shown in figure. The SCRs are triggered by a constant dc signal. If SCR 2 gets open circuited, then what will be the average charging current?

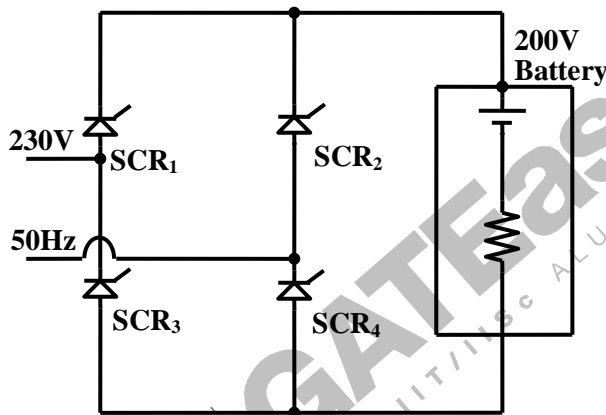

- (A) 23.8 A (C) 11.9 A
 (B) 15 A (D) 3.54 A

70. An SCR having a turn ON time of $5 \mu\text{sec}$, latching current of 50 mA and holding current of 40 mA is triggered by a short duration pulse and is used in the circuit shown in figure. The minimum pulse width required to turn the SCR ON will be

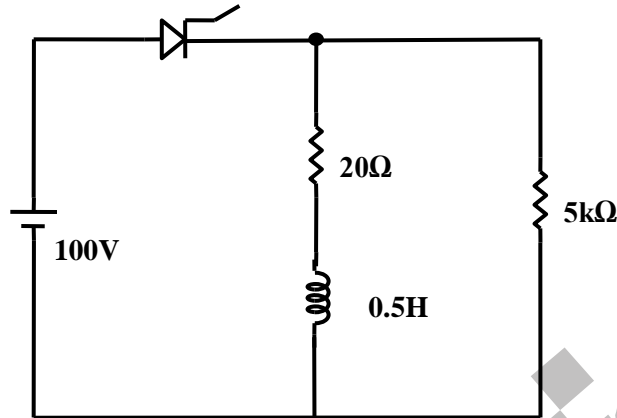

- (A) 251 μ sec
 (B) 150 μ sec
 (C) 100 μ sec
 (D) 5 μ sec

Common Data for Questions 71,72,73:

A 4 pole, 50 Hz, synchronous generator has 48 slots in which a double layer winding is housed. Each coil has 10 turns and is short pitched by an angle to 36° electrical. The fundamental flux per pole is 0.025 Wb.

71. The line – to – line induced emf (in volts), for a three phase star connection is approximately
 (A) 808
 (B) 888
 (C) 1400
 (D) 1538
72. The line-to-line induced emf (in volts), for a three phase connection is approximately
 (A) 1143
 (B) 1332
 (C) 1617
 (D) 1791
73. The fifth harmonic component of phase emf (in volts), for a three phase star connection is
 (A) 0
 (B) 269
 (C) 281
 (D) 808

Common Data for Questions 74,75:

A generator feeds power to an infinite bus through a double circuit transmission line. A 3 phase fault occurs at the middle point of one of the lines. The infinite bus voltage is 1 pu, the transient internal voltage of the generator is 1.1 pu and the equivalent transfer admittance during fault is 0.8 pu. The 100 MVA generator has an inertia constant of 5 MJ/MVA and it was delivering 1.0 pu power prior of the fault with rotor power angle of 30° . The system frequency is 50 Hz.

74. The initial accelerating power (in pu) will be
 (A) 1.0 (C) 0.56
 (B) 0.6 (D) 0.4
75. If the initial accelerating power is X pu, the initial acceleration in elect deg/sec², and the inertia constant in MJ – sec /elect deg respectively will be
 (A) 31.4X, 18 (C) X/1800, 0.056
 (B) 1800X, 0.056 (D) X/31.4, 18

Linked Answer Questions: Q-76 to Q.85 carry two marks each

Statement for Linked Answer Questions 76 and 77:

$P = [-10 \ 1 \ 3]^T$, $q = [-2 \ -5 \ 9]^T$, $r = [2 \ -7 \ 12]^T$ are three vectors

76. An orthogonal set of vectors having a span that contains p,q,r is
 (A) $[-6 \ -3 \ 6]^T$, $[4 \ -2 \ 3]^T$ (C) $[6 \ 7 \ -1]^T$, $[-3 \ 12 \ -2]^T$, $[3 \ 9 \ -4]^T$
 (B) $[-4 \ 2 \ 4]^T$, $[5 \ 7 \ -11]^T$, $[8 \ 2 \ -3]^T$ (D) $[4 \ 3 \ 11]^T$, $[1 \ 31 \ 3]^T$, $[5 \ 3 \ 4]^T$
77. The following vector is linearly dependent upon the solution to the previous problem
 (A) $[8 \ 9 \ 3]^T$ (C) $[4 \ 4 \ 5]^T$
 (B) $[-2 \ -17 \ 30]^T$ (D) $[13 \ 2 \ -3]^T$

Statement for Linked Answer Questions 78 and 79:

It is required to design an anti-aliasing filter for an 8 bit ADC. The filter is a first order RC filter with $R = 1\Omega$ and $C = 1F$. The ADC is designed to span a sinusoidal signal with peak to peak amplitude equal to the full scale range of the ADC.

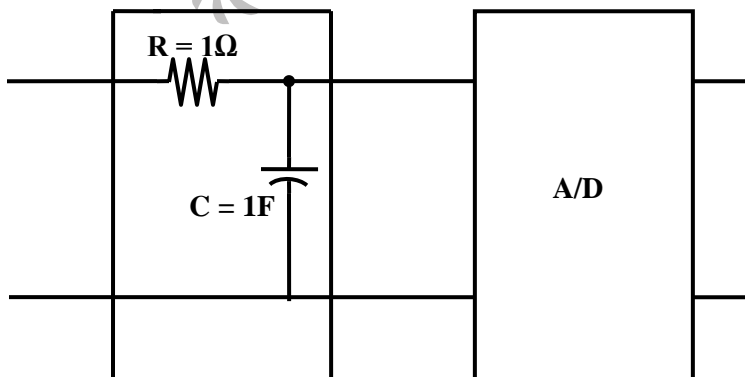

78. The transfer function of the filter and its roll off respectively are
 (A) $1/(1 + RCs)$, -20 dB / decade (C) $1/(1 + RCs)$, -40 dB / decade
 (B) $(1 + RCs)$, -40 dB/decade (D) $[RCs / (1 + RCs)]$, -20 dB / decade
79. What is the SNR (in dB) of the ADC? Also find the frequency (in decades) at the filter output at which the filter attenuation just exceeds the SNR of the ADC.
 (A) 50 dB, 2 decades (C) 60 dB, 2 decades
 (B) 50 dB, 2.5 decades (D) 60 dB, 2.5 decades

Statement for Linked Answer Questions 80 and 81:

A 300 kVA transformer has 95% efficiency at full load 0.8 pf lagging and 96% efficiency at half load, unity pf.

80. The iron loss (P_i) and copper loss (P_c) in kW, under full load operation are
 (A) $P_c = 4.12$, $P_i = 8.51$ (C) $P_c = 8.51$, $P_i = 4.12$
 (B) $P_c = 6.59$, $P_i = 9.21$ (D) $P_c = 12.72$, $P_i = 3.07$
81. What is the maximum efficiency (in %) at unity pf load?
 (A) 95.1 (C) 96.4
 (B) 96.2 (D) 98.1

Statement for Linked Answer Questions 82 and 83:

For a power system the admittance and impedance matrices for the fault studies are as follows.

$$Y_{bus} = \begin{bmatrix} -j8.75 & j1.25 & j2.50 \\ j1.25 & -6.25 & j2.50 \\ j2.50 & -j2.50 & -j5.00 \end{bmatrix}$$

$$Z_{bus} = \begin{bmatrix} j0.16 & j0.08 & j0.12 \\ j0.08 & j0.24 & j0.16 \\ j0.12 & j0.16 & j0.34 \end{bmatrix}$$

The pre-fault voltages are 1.0 p.u at all the buses. The system was unloaded prior to the fault. A solid 3 phase fault takes place at bus 2.

82. The post fault voltages at buses 1 and 3 in per unit respectively are
 (A) 0.24,0.63 (B) 0.31,0.76

(C) 0.33,0.67

(D) 0.67,0.33

83. The per unit fault feeds from generators connected to buses 1 and 2 respectively are

(A) 1.20, 2.51

(C) 1.66, 2.50

(B) 1.55, 2.61

(D) 5.00, 2.50

Statement for Linked Answer Questions 84 and 85 :

A voltage commutated chopper operating at 1 kHz is used to control the speed of dc motor as shown in figure. The load current is assumed to be constant at 10 A.

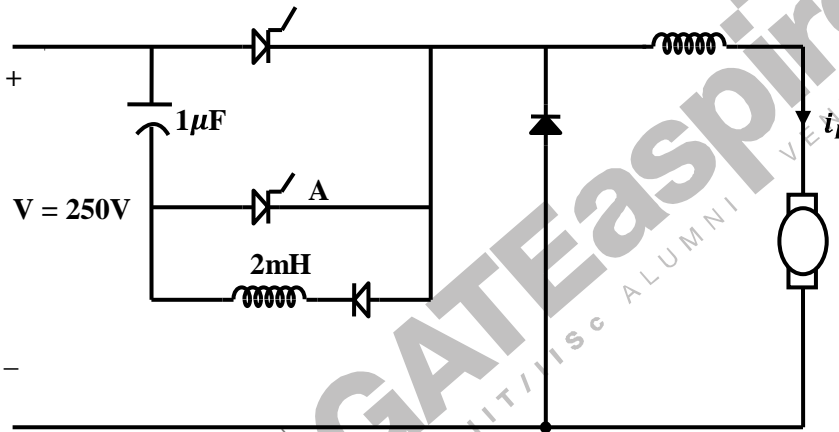

84. The minimum time in μsec for which the SCR M should be On is

(A) 280

(C) 70

(B) 140

(D) 0

85. The average output voltage of the chopper will be

(A) 70 V

(C) 35 V

(B) 47.5 V

(D) 0 V